

Overview

100% Customer Satisfaction

MaxiFlo™ smart electromagnetic flow meter is hallmarked by its high performance and reliability that are based on successful, field-proven technology. It's being widely used in industries such as petroleum, chemical engineering, iron and steel, food, electric power, paper mill, water treatment, petrochemical, medicine, etc.

Main Features

- Measurement is independent of fluid density, humidity, temperature, pressure and conductivity.
- There is no obstructive in the conduit and no pressure drop, and the straight pipe required is relatively short.
- The sensor is equipped with the advanced processing technology that provides excellent immunity to negative pressure.
- The LCD of the converter makes it easy to read during daylight and in darkness.
- Parameters can be set up using infrared touch nubs without having to open the cover of the converter.
- The converter has alarm function for self-diagnosis, empty load test, high and low limit of flow, two-stage flow value, etc.
- It's applicable not only to general process, but also in tough applications such as mining, papermaking, pastry, etc.
- High-pressure sensor adopting PFA lining technology is resistant to high pressure and negative pressure, and is especially good in industries of oil, chemistry, etc.

Measuring Principle

The measurement of flow rate of the electromagnetic flowmeter is based on Faraday's law of electromagnetic induction.

When the conductive liquid moves within the magnetic field, voltage is induced in it, whose magnitude is proportional to the velocity of the conductor.

The equation is as below;

$$E=KBVD$$

- K: Coefficient of the flowmeter
- B: Pulsed magnetic flux density
- V: Average velocity of the media
- D: Inner diameter of the measuring pipe

Please see the picture to the right.

MAXIFLO

Electromagnetic Flowmeter (Series ME)

ELECTROMAGNETIC

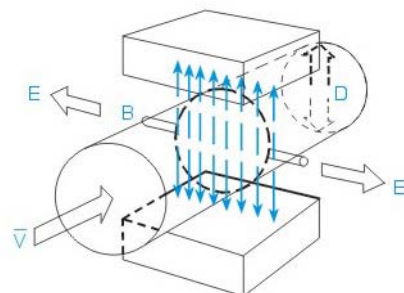

Measuring Principle of Electromagnetic Flowmeter

SMART CONVERTER

ME series Electromagnetic Flowmeter

Features and Applications

ME series smart electromagnetic flowmeter converter with new technology is made for high performance. It adopts embedded 16-bit microprocessor technology. It features normal-reverse direction flow measurement, positive or negative total flow, etc. above else. It can measure volume flow of conductive liquids such as water, sewage, acid, alkali and salt as well as mixture of liquid and solid.

Technical Specifications

ELECTROMAGNETIC



Integral Converter



Remote Converter

Power Supply:

- 220 VAC 50Hz)
- 24VDC
- Battery

Power Consumption: ≤ 20W

Display with Push Buttons: The big LCD with backlight displays percentage of flow, instantaneous flow and total flow, and alarm status.

Totalizer: It's used for calculating the accumulative total for forward and reverse flow.

Output Signal:

1. Analog Output:

- 4-20mA: Load Resistance 0 ~ 750 Ω
- 0-10mA: Load Resistance 0~1.5 KΩ

2. Frequency Output: Forward and reverse flow output with frequency range set between 1 ~ 5000Hz. The external voltage must be lower than 35V and the maximum output current is 250mA when the transistor is turned on.

3. Alarm Output: Two outputs from the collectors of photoelectric isolate transistors are for alarm signals. The external voltage must be lower than 35V and the max output current is 250mA when the transistor is turned on. Alarms are set for empty pipe, excitation circuit failure, flow limit exceeded, etc.

4. Pulse Output: For output in forward and reverse flow measurement, upper frequency of pulse output can be up to 5000 cp/s. The flow per pulse is from 0.0001 to 1.0m³/cp. The width of the pulse can be set to 20ms or square waveform automatically. The collector of transistor with photoelectric isolation is open circuited. The external voltage must be lower than 35V and maximum of output current is 250mA when the transistor is turned on.

Accuracy: ±0.5% of reading, ±0.3% or 0.2% available

Damping Time: Adjustable between 0 and 100 (90%)

Communication Interface: RS-232C, RS-485 or HART, with lightning protection

Power Failure: A fail-safe clock is designed in the flowmeter, which can save the power failure records for 16 times.

Protection: IP65/IP67 (dustproof and submersion for short time)

Ex-Proof Class: EXmdIIBT4



SENSOR (Inline type)
ME series Electromagnetic Flowmeter

Technical Specifications

Pipe Sizes: DN10 ~ DN3000 mm

Nominal Pressure: 0.6 ~ 4.0 Mpa

Accuracy: ±0.5% of reading, ±0.3% or 0.2% available

Liner Material: PTFE, PFA, FEP, Neoprene, Polyurethane, etc.

Electrode Material: SUS316L, Hastelloy-B, Hastelloy-C, Titanium, Tantalum, Platinum-iridium, Stainless steel covered with tungsten

Medium Temperature:

Rubber – -20°C ~ +70°C

Teflon (PTFE/PFA/FEP) - -40°C ~ +180°C

Polyurethane – -10°C ~ +60°C

Ambient Temperature: -25°C ~ + 60°C

Ambient Humidity: 5 ~ 100% RH

Medium Electrical Conductivity: ≥ 5 μS/cm

Measuring Range: 1500:1, flow velocity ≤ 10 m/s

Protection Class: IP65 (dustproof and watertight), IP68 (dustproof and submersible for a prolonged period of time, optional, available only for remote type)

Ex-Proof: ExmdIIBT4



ELECTROMAGNETIC

Dimensions

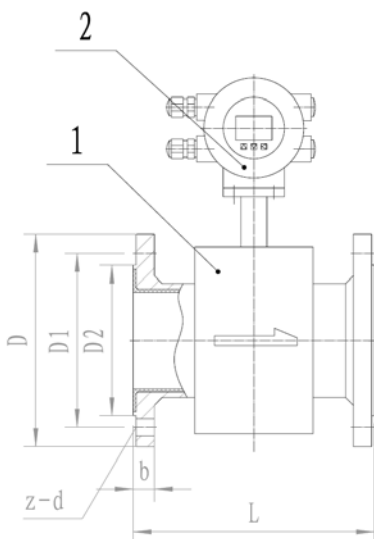

Nominal Pressure (ANSI CL)	Meter Size and Dimensions							
	inch	mm	L	D	inch	mm	L	D
150#	½	15	200	89	8	200	350	343
	¾	20	200	98	10	250	400	406
	1	25	200	108	12	300	400	482.6
	1-1/4	32	200	117	14	350	400	533
	1-1/2	40	200	127	16	400	450	597
	2	50	200	152	20	500	450	699
	2-1/2	65	200	178	24	600	600	813
	3	80	250	190	30	750	750	985
	4	100	250	229	36	900	900	1170
	5	125	250	254	40	1000	1000	1289
6	150	300	279	241.5	216	25.4	8-22	

SENSOR (Insertion type) ME series Electromagnetic Flowmeter

ELECTROMAGNETIC



Flange Type
Insertion Sensor

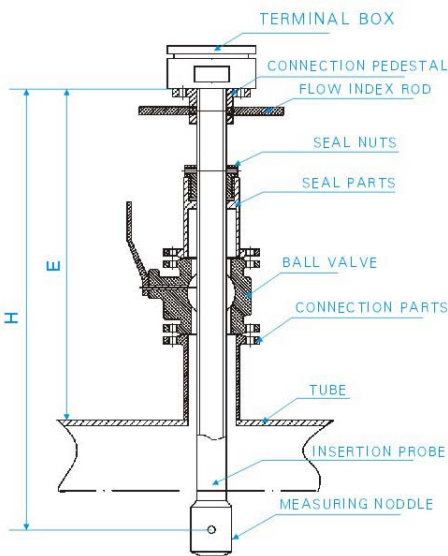

Construction of the Insertion Sensor

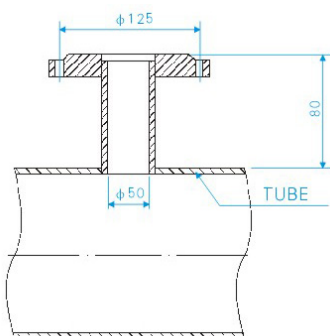

Insertion Sensor Install Dimensions

Overview

Being based on Faraday's law of electromagnetic induction, MaxiFlo ME series insertion type electromagnetic flowmeter provides high versatility and reliability with advanced, field-proven technologies. This type is used widely in the applications where the pipe size is relatively large but the high performance-price ratio is required.

Features and Applications

- Measurement is independent of fluid density, humidity, temperature, pressure and conductivity.
- There is no obstructive in the conduit, and therefore, there's no pressure damage to the pipe.
- The sensor can be installed through a hot-tapped insertion hole and therefore doesn't need to stop the process flow for installation. This makes it most suitable in fields where the water can't be shut off for long. In addition, it can be installed on the old pipes with local hatching.
- Because it doesn't have lining to affect the accuracy, it's more reliable and accurate as compared to inline type sensors.
- The wide range of pipe size makes it suitable for all the pipe sizes between DN300 and DN3000
- The integral grounded electrode guarantees good grounding.
- The sensor with advanced process technology guarantees high precision and stability.

Technical Specifications

Pipe Sizes: DN300 ~ DN3000 mm

Nominal Pressure: 1.6 Mpa

Accuracy: ±1.5% of reading

Electrode Material: SUS316L, Hastelloy-B, Hastelloy-C

Electrode Enclosure Material: PVC, ABS, Polypropylene, etc.

Measuring Probe Material: Carbon Steel, SUS304

Medium Temperature: PVC/ABS: 10°C ~ +60°C, Polypropylene: ~+80°C

Ambient Temperature: -25°C ~ + 60°C

Ambient Humidity: 5 ~ 95% RH

Atmospheric Pressure: 86 ~ 106 KPa

Straight Pipe Length Required: 10D upstream, 5D downstream

Protection Class: IP65, IP68 (Optional)

Connection: Flange

Ex-Proof: ExmdIIBT4

SELECTION PRINCIPLES

ME series Electromagnetic Flowmeter

The medium being measured must be conductive liquid whose electrical conductivity should be more than 5 $\mu\text{S}/\text{cm}$. The medium shouldn't contain much magnetic matter or air bubble. Pressure rating, lining material, electrode material and the configuration type should be selected according to the medium's temperature, corrosiveness, abrasiveness, etc. Also, the following points should be considered;

- Normally, the size of the meter should be the same as the pipe size.
- Recommended flow velocity is 1 ~ 3 m/s if the medium contains particles. If the actual flow velocity is too big, then select higher size to reduce the flow velocity and the abrasion onto the pipe wall.
- Recommended flow velocity is 2 ~ 5 m/s if there is deposit in the pipe. Select lower meter size to increase the flow velocity and reduce the negative influence on the accuracy by the deposit if the actual flow velocity is too low and if it's not easy to change the pipe.
- If the flow velocity is too small and a high accuracy is required, then smaller meter size is recommended to increase the flow velocity and ensure the accuracy.

VELOCITY-FLOW RATE TABLE

Pipe Size		Min. Flow Rate (0 ~ 0.5 m/s)	Max. Flow Rate (0 ~ 10 m/s)
mm	Inch	l/min, m ³ /h	l/min, m ³ /h
10	3/8	0 ~ 2 l/min	0 ~ 40 l/min
15	1/2	0 ~ 5 l/min	0 ~ 100 l/min
20	3/4	0 ~ 7.5 l/min	0 ~ 150 l/min
25	1	0 ~ 10 l/min	0 ~ 200 l/min
32	1.25	0 ~ 20 l/min	0 ~ 400 l/min
40	1.5	0 ~ 30 l/min	0 ~ 600 l/min
50	2	0 ~ 3 m ³ /h	0 ~ 60 m ³ /h
65	2.5	0 ~ 6 m ³ /h	0 ~ 120 m ³ /h
80	3	0 ~ 9 m ³ /h	0 ~ 180 m ³ /h
100	4	0 ~ 12 m ³ /h	0 ~ 240 m ³ /h
125	5	0 ~ 21 m ³ /h	0 ~ 420 m ³ /h
150	6	0 ~ 30 m ³ /h	0 ~ 600 m ³ /h
200	8	0 ~ 54 m ³ /h	0 ~ 1080 m ³ /h
250	10	0 ~ 90 m ³ /h	0 ~ 1800 m ³ /h
300	12	0 ~ 120 m ³ /h	0 ~ 2400 m ³ /h
350	14	0 ~ 165 m ³ /h	0 ~ 3300 m ³ /h
400	16	0 ~ 225 m ³ /h	0 ~ 4500 m ³ /h
450	18	0 ~ 300 m ³ /h	0 ~ 6000 m ³ /h
500	20	0 ~ 330 m ³ /h	0 ~ 6600 m ³ /h
600	24	0 ~ 480 m ³ /h	0 ~ 9600 m ³ /h
700	28	0 ~ 660 m ³ /h	0 ~ 13200 m ³ /h
800	32	0 ~ 900 m ³ /h	0 ~ 18000 m ³ /h
900	36	0 ~ 1200 m ³ /h	0 ~ 24000 m ³ /h
1000	40	0 ~ 1350 m ³ /h	0 ~ 27000 m ³ /h

MODEL SELECTION CODE TABLE

ME series Electromagnetic Flowmeter

ELECTROMAGNETIC

ME-###-#-#-##-##-##-Options		Code
Size		DN size
Installation Type	Integral	I
	Remote	R
	No Display	N
Sensor Type	Inline Sensor	G
	Insertion Sensor	I
Power Supply	90~245VAC, 50Hz	P1
	20~36VDC	P2
	Battery	P3
Electrode Material	SUS 316L	E1
	Hastelloy-B	E2
	Hastelloy-C	E3
	Titanium	E4
	Pt-Iridium Alloy	E5
	Tantalum	E6
	316L with Carbide Coating	E7
Lining Material	FEP	L1
	PTFE	L2
	PFA	L3
	Chloroprene Rubber	L4
	Polyurethane	L5
Connection Type	JIS Flange	F1
	ANSI Flange	F2
	DIN Flange	F3
	NPT Thread (Male)	F4
	Others	FX
Options	Heat Meter Function	/H
	HART	/HT
	Foundation Fieldbus	/FF
	Earth Ring	/GR
	Ex-Proof	/EX
	Cable Length in m	/C_____

MAXIFLO